

Tutorials

Tutorial 2 - Hydraulic Cylinder Drive

Objective

In this tutorial you will create a model for a simple hydraulic cylinder drive, which is controlled by a proportional directional control valve. In a first step you will create an Open-Loop System, which means that there is no feedback of the actual cylinder position to the control valve. In a second step, the position of the cylinder is measured and compared to the position command signal, in order to create a Closed-Loop System.

The purpose of the circuit is to lift (or lower, respectively) the load mass in vertical direction, according to the command signal of the proportional directional control valve. For the pressure supply, we simply use a constant displacement pump, driven at a constant speed and connected to a pressure relief valve. The advantage of this system is its simple structure. Of course, it shows a very poor efficiency, since a great amount of energy is consumed by the flow through the relief valve.



It is assumed that you are familiar with the basic functionality of SimulationX. Therefore, please refer to "Tutorial 1: Getting Started" for a general introduction on how to select Elements from the libraries, how to connect them and enter parameters, how to run a simulation and how to open result windows.

Part 1: Open-Loop System

Create the SimulationX model of the hydraulic cylinder drive according to Figure 1. Use the elements listed in Table 1. You can change the label text and label position of each object by double clicking on an element and selecting "General/Name ...". You have to write the name without a blank (e.g. "CylinderDrive"). When connecting the elements with each other, you should remember, that in SimulationX you can only connect element ports of the same type.

The mass of the cylinder piston is not included in the cylinder object. So you have to model the piston mass by connecting an element "Mass" (Library Mechanics → Linear Mechanics → Mass) to the cylinder. It represents the piston mass as well as the load mass at the same time.

In order to cut an already existing connection, click on it and press "Del".

The path of a connection will be determined automatically, but changing the path is possible at any time. To do this, move the mouse over a connection, while pressing the Alt-key. The mouse pointer shows you in which direction you can move the selected connection line.

- *Multi domain modeling*
- *Development from simple to extend model*
- *Controlling structures of cylinder drives*
- *Result analysis and behavior improvement*
- *Parameter studies*

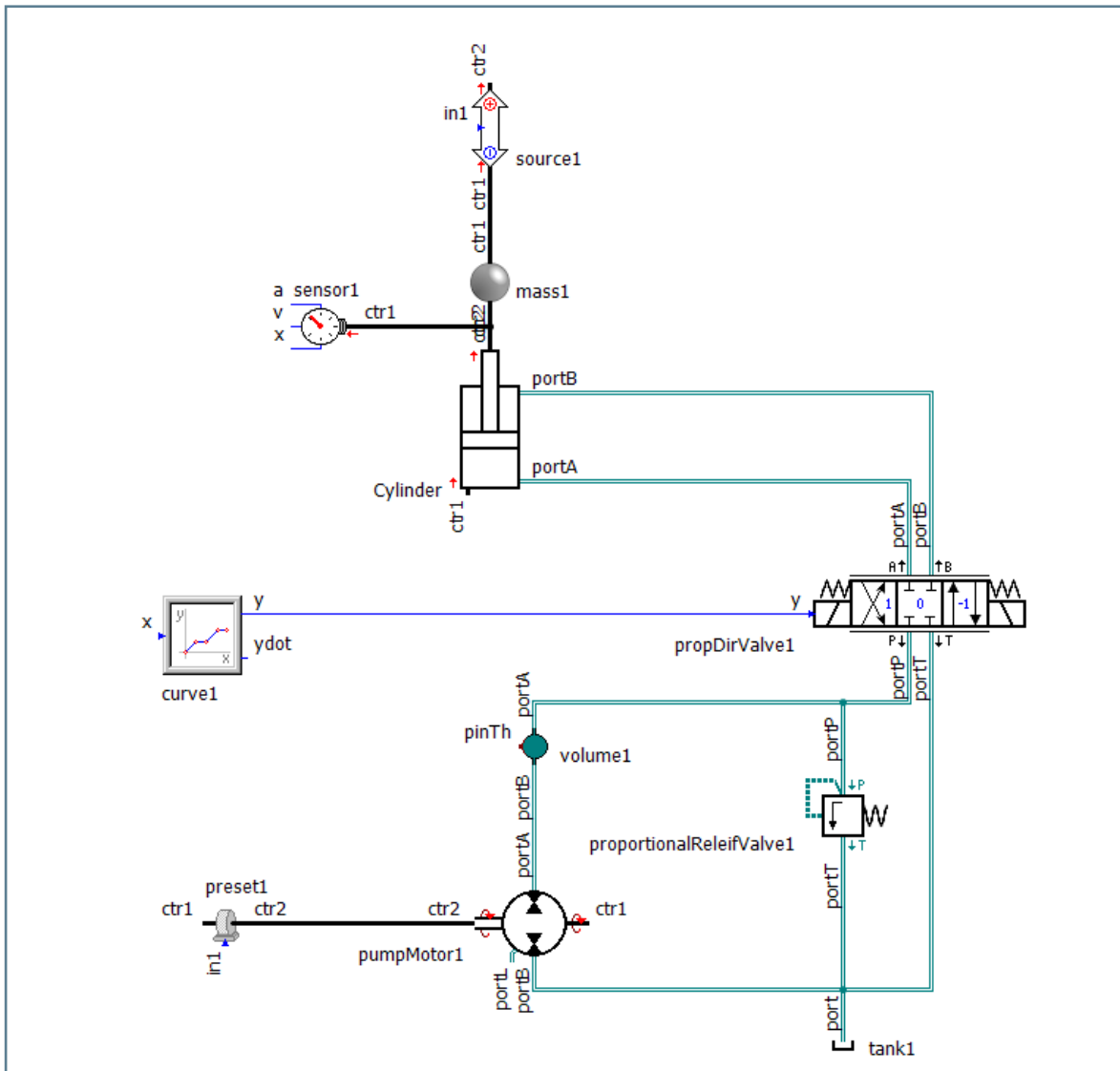











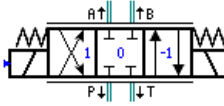









Figure 1: Model structure of the Open-Loop Cylinder Drive





Table 1: Elements required for the circuit in Figure 1





Number of elements	Library name	Element name	Symbol
1	Hydraulics/ Actuators	diffCylinder1 	
1	Hydraulics/ Actuators	pumpMotor1 	
1	Hydraulics/ Basic Elements	volume1 	
1	Hydraulics/ Valves/ Pressure Valves	pressureReliefValve1 	
1	Hydraulics/ Basic Elements	tank1 	

1	Hydraulics/ Valves/ Proportional Directional Control Valves	propDirValve1 	
1	Mechanics/ Linear Mechanics	mass1 	
1	Mechanics/ Linear Mechanics	source1 	
1	Mechanics/ Rotational Mechanics	preset1 	
1	Signal Blocks/ Signal Sources	curve1 	

Once you have succeeded in creating the model structure according to Figure 1, you have to enter the parameters for the elements and activate the protocol attribute for the variables which you want to plot after the simulation. Since almost all elements have default parameters, you only have to enter the parameters which are different from the default values. Table 2 gives an overview about the parameter settings which you have to enter. Some of the parameter dialogs have more than one page.

Table 2: Parameter settings for the elements listed in Table 1

Element	Parameter Input																																							
 Cylinder (diffCylinder1) 	Dialog Page "Geometry": <ul style="list-style-type: none"> Set the Maximum Cylinder Stroke to 400 mm <table border="1" data-bbox="639 1182 1370 1227"> <tr> <td>Maximum Stroke</td> <td>maxStroke:</td> <td>400</td> <td>mm</td> </tr> </table> Set the "Dead Volume" at Port A and B to 1 dm³ (select appropriate unit first and enter the value secondly) <table border="1" data-bbox="639 1317 1370 1361"> <tr> <td>Dead Volume Port A</td> <td>vol0A:</td> <td>1</td> <td>dm³</td> </tr> <tr> <td>Dead Volume Port B</td> <td>vol0B:</td> <td>1</td> <td>dm³</td> </tr> </table> Set the "Transformation of Piston Housing" to -200 mm <table border="1" data-bbox="639 1473 1370 1518"> <tr> <td>Transfer of Coordinates</td> <td>dxh:</td> <td>-200</td> <td>mm</td> </tr> </table> <p>The coordinate transformation dxh of -200 mm means, that the displacement of the "Mass" is zero while the piston stroke is 200 mm. It sets the center of the mass to the half of the piston stroke.</p> Dialog Page "Friction": <table border="1" data-bbox="639 1653 1370 1697"> <tr> <td>Friction Description</td> <td>cylFriction:</td> <td>No Friction Losses</td> </tr> </table> Dialog Page "Results 2": <ul style="list-style-type: none"> Activate the result attributes  ->  <table border="1" data-bbox="639 1794 1370 2033"> <tr> <td>Pressure Chamber A</td> <td>pA:</td> <td><input checked="" type="checkbox"/></td> <td>bar</td> </tr> <tr> <td>Pressure Chamber B</td> <td>pB:</td> <td><input checked="" type="checkbox"/></td> <td>bar</td> </tr> <tr> <td>Pressure Drop A -> B</td> <td>pAB:</td> <td><input type="checkbox"/></td> <td>bar</td> </tr> <tr> <td>Volume Flow Port A</td> <td>QA:</td> <td><input checked="" type="checkbox"/></td> <td>l/min</td> </tr> <tr> <td>Volume Flow Port B</td> <td>QB:</td> <td><input checked="" type="checkbox"/></td> <td>l/min</td> </tr> </table> 	Maximum Stroke	maxStroke:	400	mm	Dead Volume Port A	vol0A:	1	dm ³	Dead Volume Port B	vol0B:	1	dm ³	Transfer of Coordinates	dxh:	-200	mm	Friction Description	cylFriction:	No Friction Losses	Pressure Chamber A	pA:	<input checked="" type="checkbox"/>	bar	Pressure Chamber B	pB:	<input checked="" type="checkbox"/>	bar	Pressure Drop A -> B	pAB:	<input type="checkbox"/>	bar	Volume Flow Port A	QA:	<input checked="" type="checkbox"/>	l/min	Volume Flow Port B	QB:	<input checked="" type="checkbox"/>	l/min
Maximum Stroke	maxStroke:	400	mm																																					
Dead Volume Port A	vol0A:	1	dm ³																																					
Dead Volume Port B	vol0B:	1	dm ³																																					
Transfer of Coordinates	dxh:	-200	mm																																					
Friction Description	cylFriction:	No Friction Losses																																						
Pressure Chamber A	pA:	<input checked="" type="checkbox"/>	bar																																					
Pressure Chamber B	pB:	<input checked="" type="checkbox"/>	bar																																					
Pressure Drop A -> B	pAB:	<input type="checkbox"/>	bar																																					
Volume Flow Port A	QA:	<input checked="" type="checkbox"/>	l/min																																					
Volume Flow Port B	QB:	<input checked="" type="checkbox"/>	l/min																																					

<p>Mass (mass1)</p> 	<ul style="list-style-type: none"> Set the mass to 100 kg <p>Mass m: <input type="text" value="100"/> kg</p> <ul style="list-style-type: none"> Set the initial displacement and velocity to zero <p>Initial Displacement x0: <input type="text" value="0"/> mm</p> <p>Initial Velocity v0: <input type="text" value="0"/> m/s</p> <ul style="list-style-type: none"> Activate the protocol attribute <p>Displacement x: <input type="checkbox"/> m</p> <p>Velocity v: <input type="checkbox"/> m/s</p>
<p>GravityForce (source1)</p> 	<ul style="list-style-type: none"> Set the force to $(mass1.m * 9.81)$ N <p>Force F: <input type="text" value="mass1.m*9.81"/> N</p> <p><i>Note, that in SimulationX you can enter constant values as well as arithmetical and/or Boolean expressions, variables and functions for any parameter. In the case above, the expression considers the gravity force of mass1.m (100) kg.</i></p> <p><i>When using the "External Force" element, you have to decide whether to connect the left or the right side to the mechanical element (i.e. mass). In our case, we have connected the left side of the force to the mass (see Figure 1). This means, that the force will act against the positive direction of motion of the mass. The small red arrows indicate the positive coordinate direction of the element (mass), the positive coordinate direction of the force is indicated by the big white arrows.</i></p> <ul style="list-style-type: none"> Activate the protocol attributes for the force : <p>Internal Force Fi: <input type="checkbox"/> N</p>
<p>Pump (pumpMotor1)</p> 	<p>Dialog page "Geometry" :</p> <ul style="list-style-type: none"> Set the displacement volume to 50 cm³ <p>Displacement Volume Vd: <input type="text" value="50"/> cm³</p> <p>Dialog page "Friction" :</p> <p>Friction Description frKind: No Friction Losses</p> <p>Dialog page "Leakage" :</p> <p>Leakage Description lKind: No Leakage</p> <p>Dialog page "Results₂" :</p> <ul style="list-style-type: none"> Activate the protocol attribute for the flow at port A <p>Effective Volume Flow ... Q_{effA}: <input type="checkbox"/> l/min</p>
<p>Motor (preset1)</p> 	<p>Dialog page "Parameters" :</p> <ul style="list-style-type: none"> Select the kind "Rotational Speed" <p>Kind kind: Rotational Speed</p> <ul style="list-style-type: none"> Select at first the unit "rpm" and then the value for the rotational speed <p>Rotational Speed om: <input type="text" value="1000"/> rpm</p> <ul style="list-style-type: none"> Activate the protocol attributes for "Torque" and "Power"

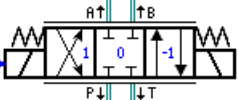
	<p>Torque T: <input checked="" type="checkbox"/> Nm</p> <p>External Power Pe: <input checked="" type="checkbox"/> Nm/s</p>
<p><i>ReliefValve (pressureReliefValve1)</i></p> 	<p>Activate the protocol attribute for the result variables "Pressure Drop", "Volume Flow" and "Power Dissipation"</p> <p>Pressure Drop P->T pPT: <input checked="" type="checkbox"/> bar</p> <p>Volume Flow P->T (meter-in) Q: <input checked="" type="checkbox"/> l/min</p> <p>Mass Flow mdot: <input checked="" type="checkbox"/> kg/s</p> <p>Power Dissipation Pdiss: <input checked="" type="checkbox"/> kW</p>
<p><i>ProportionalControlValve (propDirValve1)</i></p> 	<p>Dialog page "Stroking":</p> <ul style="list-style-type: none"> In the selection box "Stroke Signal" select "Normalized Signal" <p>Stroke Signal strokeDescr: Normalized Signal (-1 ... 1)</p> <p>Note, that "Normalized Signal" means the valid range of the input signal must be from -1 to +1. At an input signal of zero the valve will be in its center position.</p> <p>Dialog page "Dynamics":</p> <ul style="list-style-type: none"> Turn off the check box for the valve dynamics <p><input type="checkbox"/> Consider Valve Dynamics</p> <p>Dialog page "Q-y-Function":</p> <ul style="list-style-type: none"> In the selection box "Type of Edges" select "Identical Edges" <p>Type of Edges edgesEnum: Identical Edges</p> <ul style="list-style-type: none"> Set the flow per change of Stroke to (60 l/min)/- <p>Change the unit to (l/min)/- firstly.</p> <p>Flow per Stroke dQdy: 60 (l/min)</p> <p>Note: A value of 60 (l/min)/- means, that we will have a flow of 60l/min at a pressure drop of 35 bar (at one single edge) for full valve opening stroke.</p> <p>Dialog page "Results":</p> <ul style="list-style-type: none"> Activate the protocol attribute for the "Relative Valve Stroke" <p>Relative Valve Stroke yRel: <input checked="" type="checkbox"/> %</p> <ul style="list-style-type: none"> Activate the protocol attribute for the flow at port A & B <p>Volume Flow Port A QA: <input checked="" type="checkbox"/> l/min</p> <p>Volume Flow Port B QB: <input checked="" type="checkbox"/> l/min</p> <ul style="list-style-type: none"> Activate the protocol attribute for "Power Dissipation" <p>Power Dissipation Pdiss: <input checked="" type="checkbox"/> kW</p> <p>The power Dissipation allows you to investigate the overall efficiency of your system.</p>
<p><i>ControlSignal (curve1)</i></p>	<p>Dialog "Parameters":</p> <ul style="list-style-type: none"> Select "Simulation Time t [s]" <p>Reference Value RefVar: Simulation Time t [s]</p>



- Click the "Edit" button to open the dialog for the "Input of Values"

Curve curve:

- Select the quantity and the labels for the axis by using the "Properties" button  in the toolbar

Properties

Comment	Quantity	Approximation Tolerance
x	Time	
y[1]	Unitless	0.1

- Base Quantities
- Geometric Quantities
- Mechanics (Linear)
- Mechanics (Rotary)
- Electricity
- Pneumatics
- Acoustics
- Hydraulics
- Thermofluidics
- Thermodynamics
- Electro-Mechanics

-
- Unitless
- Geometric Dimensions
- Number of Pieces
- Frequency
- Time
- Relative Magnitude
- Gradient
- Reciprocal Temperature
- Data Width
- Reciprocal Temperature Squa

In the "Properties"- window you have to enter the comments and the quantities for the axes.

Enter for the X-axis the simulation time and for the Y-axis as comment "Signal Output" and quantity –"Base Quantities/ Relative Magnitude".

- Enter the following data and click OK when finished:

Curve curve (curve1)

Simulation time [s]	Signal Output [-]
0	0
0.1	-1
0.3	-1
0.4	0
0.5	0
0.6	1
0.8	1
0.9	0
1	0

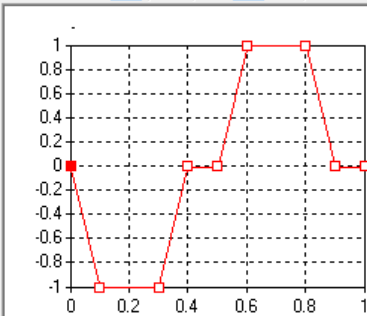

You can also load existing data from ASCII files or double-click directly on the graphic on the right. Alternatively, you can use other elements from the library "Signal Sources".

- Activate the protocol attribute for the result variable "Signal Output".

Signal Output y:

VP (volume₁)



Dialog page "Parameters" :

- Set the volume to 1 dm³

Volume V:

Note, that volumes are not required in SimulationX. However a pump volume of zero would result in an infinitely fast pressure change, which is not realistic.

Dialog page "Results" :

- Activate the protocol attribute for the pressure

Pressure p:



Let the settings of simulation as default. Once you have entered the parameters of the model, you can run the simulation and observe the results. Figure 2 shows some of the simulation results. You can also change the hydraulic fluid by double-clicking on the connection and selecting a liquid. The default is "HLP 46", a mineral oil with a viscosity behavior according to ISO VG 46.

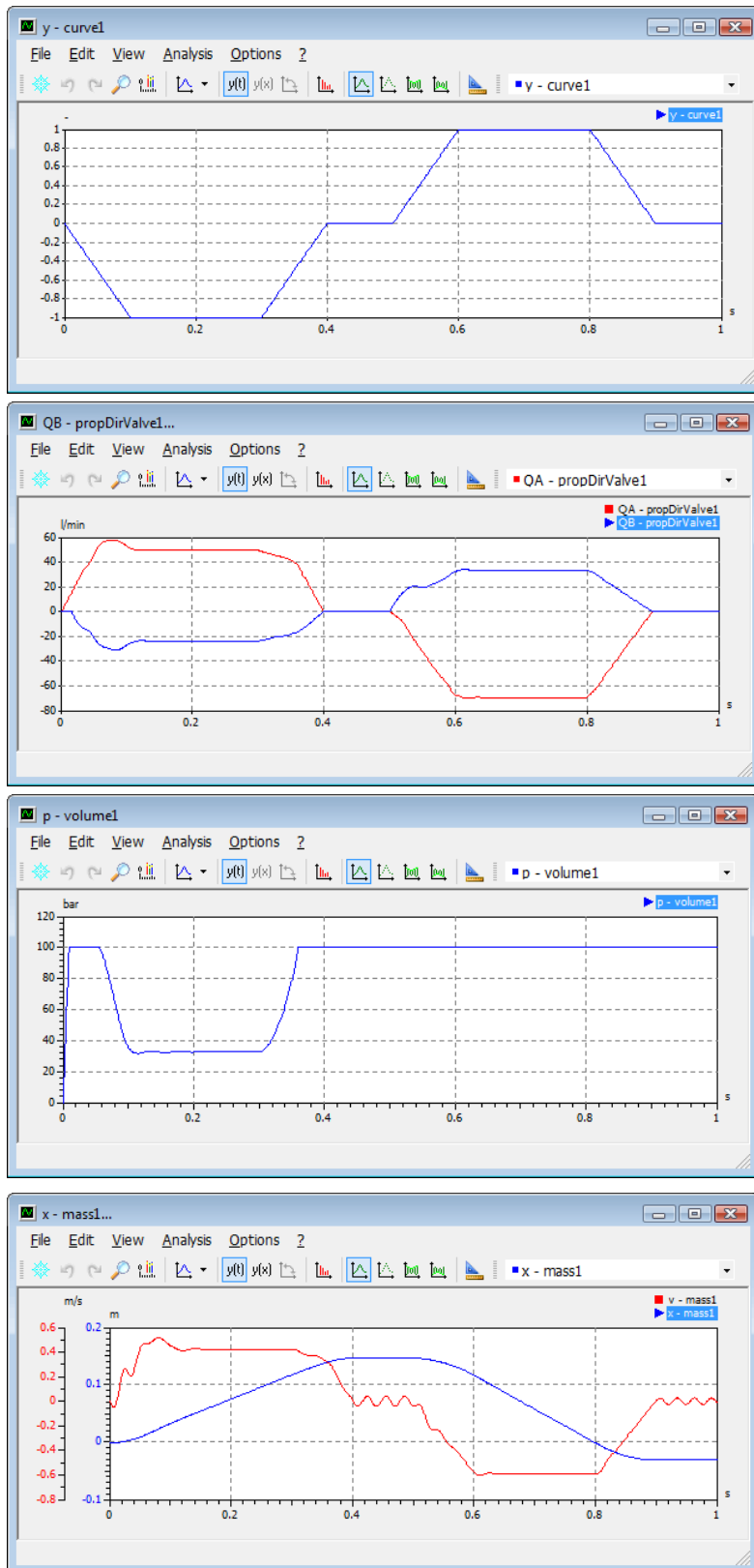

Figure 2: Simulation results for the open-loop cylinder drive

The control signal shows the specified characteristics. If the stroke signal for the valve is negative, the pump is connected to Port A of the cylinder, i.e. the load mass is lifted up.

The flow at Port A and B of the valve is somehow proportional to the stroke signal. Because we have a differential cylinder, the flow shows an unsymmetrical behavior. The maximum positive flow can not exceed 50 l/min, which is the flow of the pump.

The pressure in volume "VP" can not exceed 100 bar, which is the set pressure for the relief valve. At full negative opening of the control valve, the pump pressure "VP" drops to 32 bar, since the pump can not deliver enough flow.

The velocity of the piston is proportional to the flow in the valve. As the pump pressure drops from 100 bar to 32 bar, the velocity also decreases slightly. When the control valve is closed, the piston oscillates because of the oil compressibility.



You can play with the simulation model, in order to improve the performance of the open-loop cylinder drive. (Don't forget to reset the model before you make modifications!) Some interesting changes in the behavior of the system should become obvious, if you

- change the set pressure in the relief valve p_{Set} from 100 bar to 200 bar, and
- use a smaller proportional control valve (i.e. change the "Flow per Change of Stroke" from 60 (l/min)/- to 20 (l/min)/-)

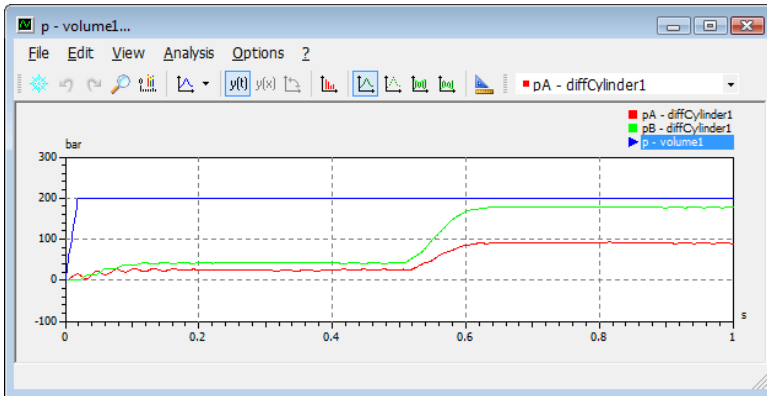

Especially with the last modification, the pump pressure will remain constant since the flow demand of the cylinder is now decreased.

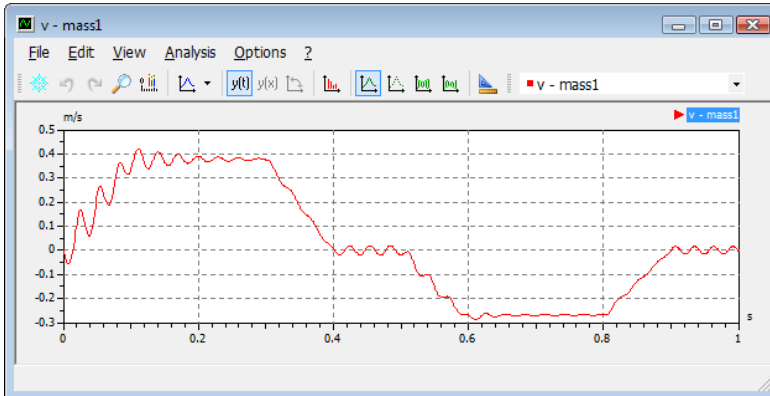

Figure 3: Improved pressure and velocity characteristic with smaller control valve

Part 2: Adding an Accumulator

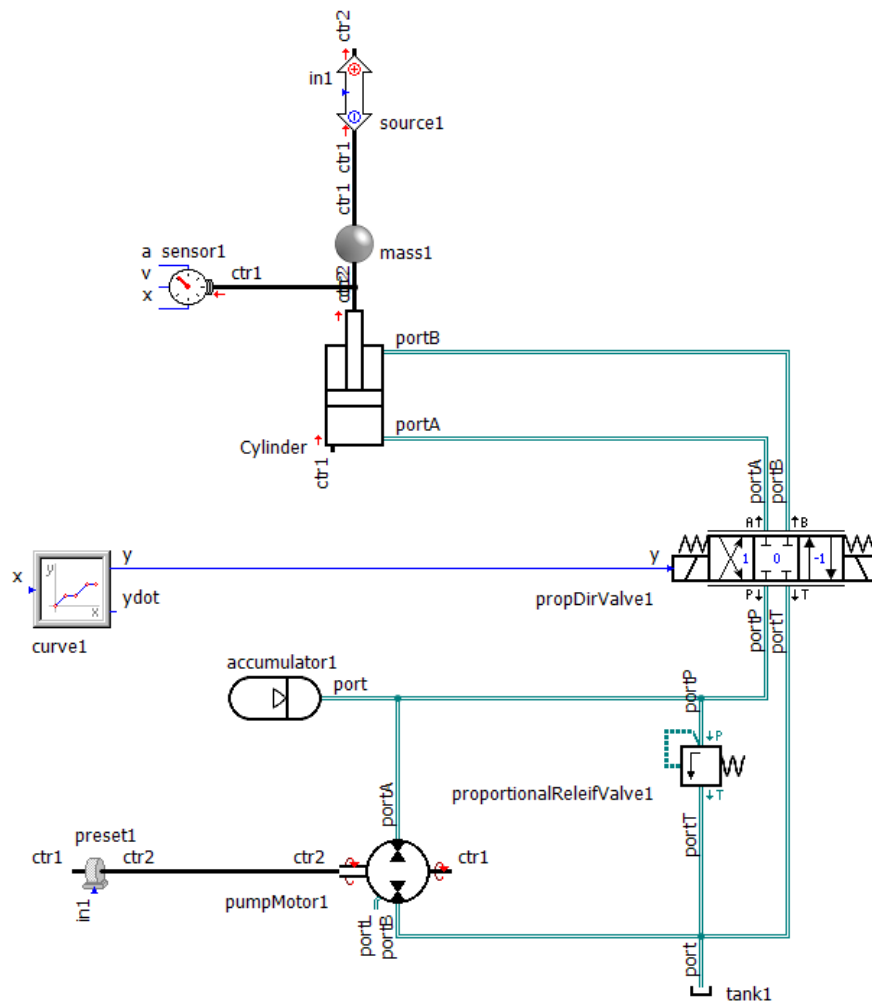

Figure 4: Modified model structure with accumulator

You will now add an accumulator to the system in order to compensate for short flow demands from the cylinder, which exceed the flow of the pump. Before you will do this, please reset the parameter "Flow per Change of Stroke" of the Proportional Control Valve from 20 (l/min)- to 60 (l/min)- and the set pressure in the relief valve to 100 bar.

To add the accumulator to the model, carry out the following steps:



- Reset the simulation model. ()
- Delete the volume VP.
- Open the library "Hydraulics" (Accessories and Sensors) and connect the "Hydropneumatic Accumulator"  according to Figure 4:

Table3: Accumulator parameters

<p>Accu (accumulator1)</p> 	<p>Dialog page "Construction 1":</p> <ul style="list-style-type: none"> • Set construction type to "Bladder Accumulator (vertical)" <p>Construction Type geomType: Bladder Accumulator (vertical)</p> <ul style="list-style-type: none"> • Set the accumulator gas volume to 5 dm³ <p>Accumulator Volume VGasF: 5 dm³</p>
--	--

- Set the "Pre-Fill Pressure" to 80 bar

Pre-Fill Pressure pGasF: 80 bar

- Set the dead volume at oil-side to 100 cm³

Dead Volume at Oil-Si... VOil0: 100 cm³

Dialog page "Operating Conditions" :

- Set the "Initial Oil Pressure" to 100 bar

Initial Oil Pressure pOil0: 100 bar

Dialog page "Results 1" :

- Activate the protocol attribute for "Oil Pressure"

Oil Pressure (relative to ... pOil: bar

- Activate the protocol attribute for "Volume Flow of Oil"

Volume Flow of Oil int... QOil: l/min

- Activate the protocol attribute for "Gas Pressure"

Gas Pressure (relative t... pGas: bar

- Activate the protocol attribute for "Gas Volume"

Gas Volume VGas: dm³

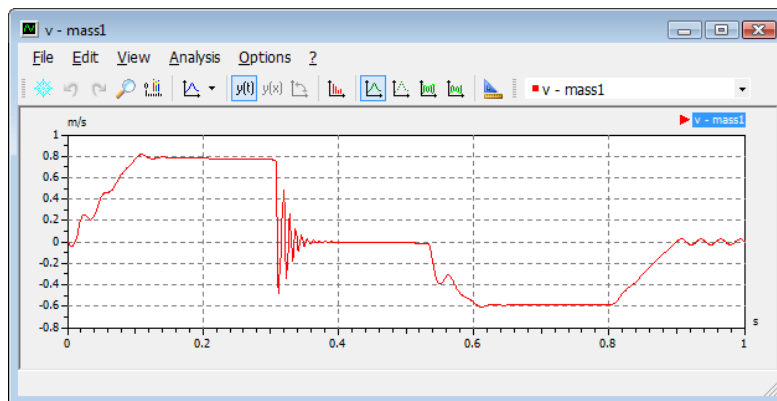

Figure 5: Improved velocity with the accumulator

If you run the simulation, you will find that the cylinder reaches its end stop after 0.3 s. At this moment, the velocity of the piston starts to oscillate with a very high frequency, because of the high end-stop stiffness of the cylinder.

It would now be possible to adapt the stiffness and the damping of the cylinder end stop to the force of the cylinder and to the piston and load mass. However, you will rather make the system a closed-loop cylinder drive.

Part 3: Closed-Loop System

For many industrial applications, an open-loop cylinder drive is not sufficient. Closed-loop systems are used in such cases. You can easily enhance the given example of the cylinder drive to make it a closed-loop drive. Add the new objects as shown in Figure 6 and listed in Table 4.

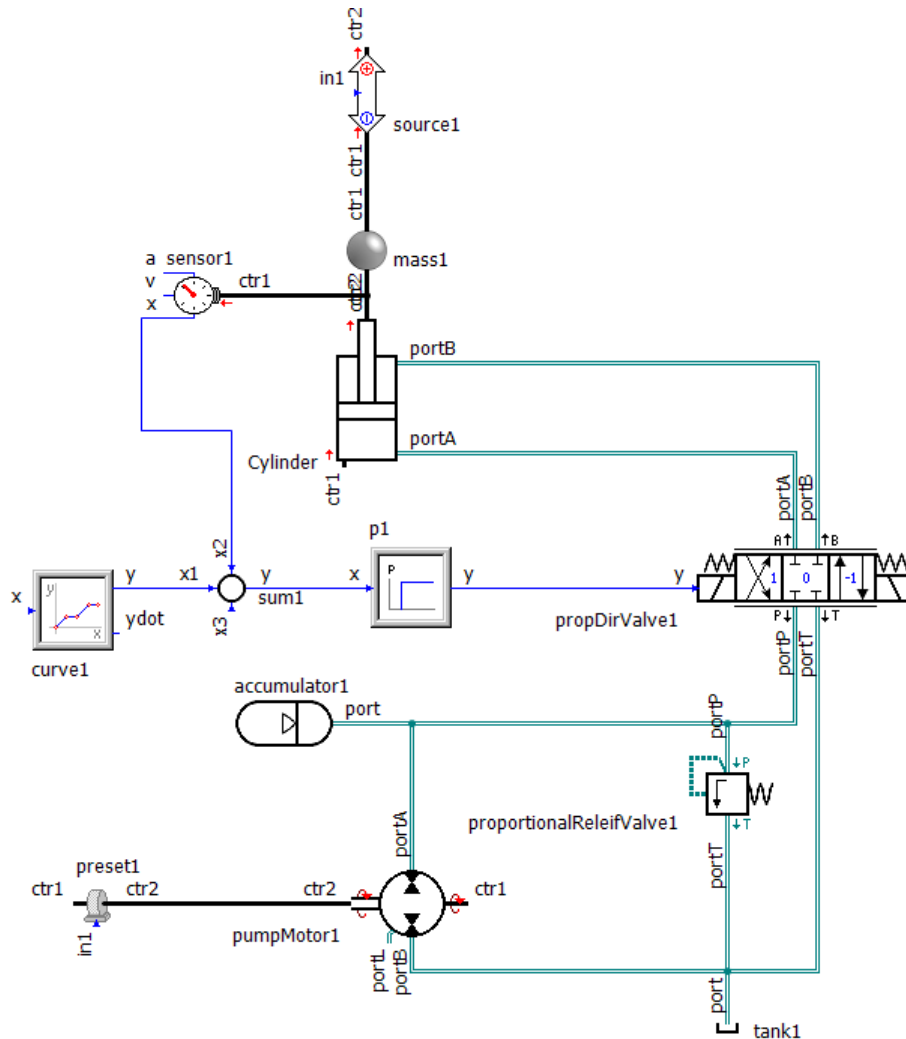









Figure 6: Closed-loop cylinder drive

Table 4: New objects needed for the closed-loop system

Object	Library	Parameters									
Sensor (sensor1) 	Mechanics 	None									
PistonError (sum1) 	Signal Blocks 	<ul style="list-style-type: none"> Set the sign switches as follow <table border="1" style="width: 100%; border-collapse: collapse;"> <tr> <td style="width: 150px;">x1</td> <td style="width: 100px;">X1Var:</td> <td style="width: 100px;">-</td> </tr> <tr> <td>x2</td> <td>X2Var:</td> <td>+</td> </tr> <tr> <td>x3</td> <td>X3Var:</td> <td style="background-color: #007bff; color: white;">+</td> </tr> </table> <p>Note, that for controlling the process we have to compare the real displacement with the given displacement.</p> <ul style="list-style-type: none"> Activate the protocol attribute for the output signal 	x1	X1Var:	-	x2	X2Var:	+	x3	X3Var:	+
x1	X1Var:	-									
x2	X2Var:	+									
x3	X3Var:	+									

		Signalausgang y:  -
Gain (p1) 	Signal Blocks/Linear Signal Blocks 	default

As the next step, you have to adapt the data table for the command signal from a relative quantity (-) to a displacement signal (mm). To do this, open the parameter dialog for the model object "CommandSignal" and proceed as follows:

- Open the curve editor window by clicking on the "Edit"-Button in the dialog "Parameters"

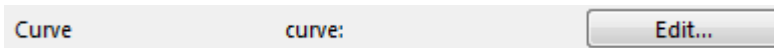

- Edit the unit by clicking on "Properties"-Button 

Define the quantity of the signal output as displacement:

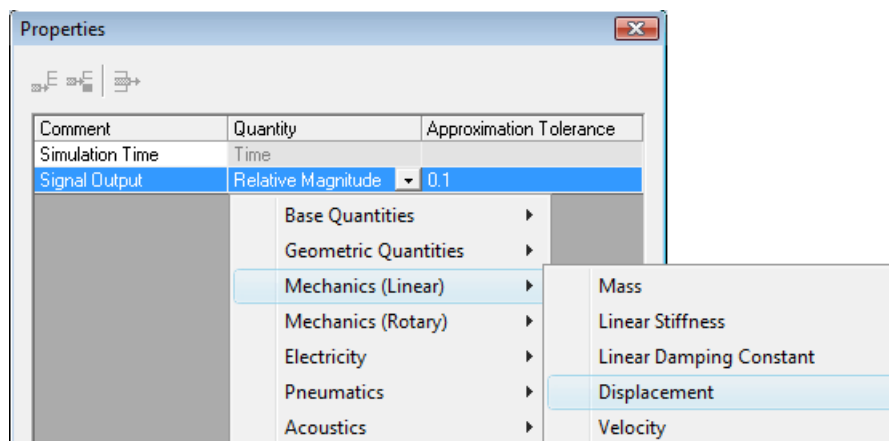

Adapt the values of the table to a maximum of 100 mm:

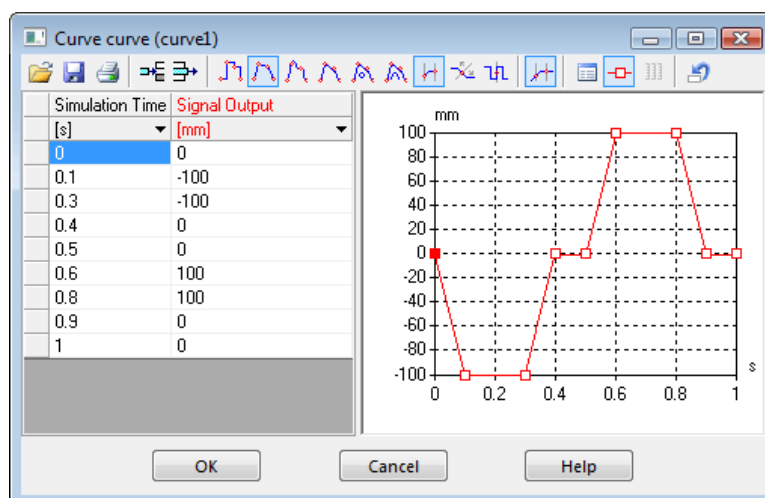

Close the curve editor window with OK.

Now you have finished the parameter entry and we can run the simulation.

You have changed the signal from a command signal to a position signal. It means another behavior as before, because you now control the position and not the signal for the ProportionalControlValve.

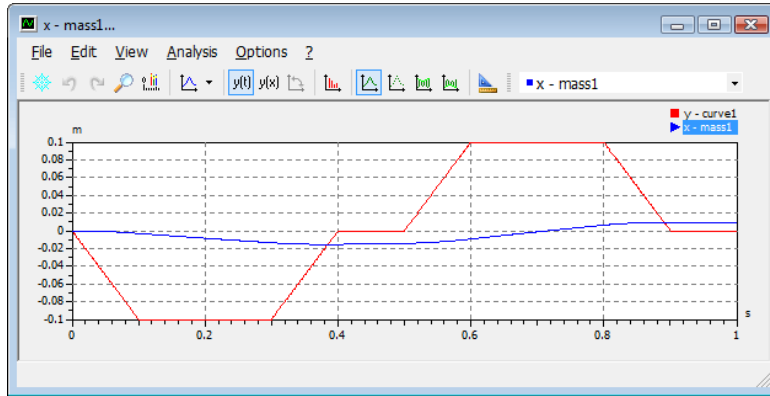

It shows the result of the piston displacement compared to the value of the command signal.

It can be observed, that the sign of the gain is OK but the value of 1 is too small.

Figure 7: Simulation Result for the closed-loop cylinder drive with a gain of 1

So let us increase the gain of the signal block "Gain" from 1 to 50:

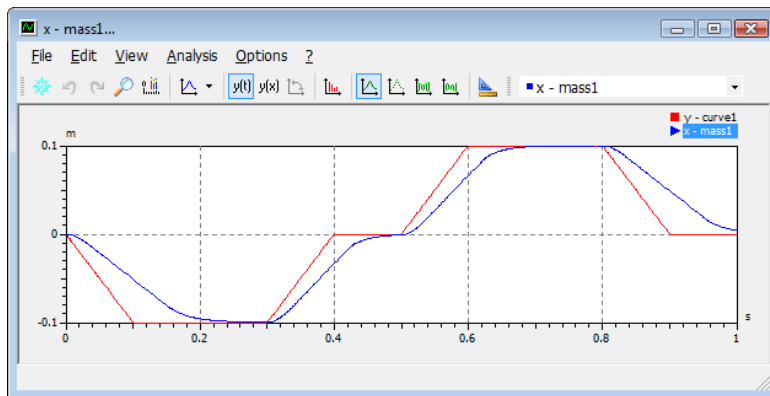

If you run the simulation again, you can observe that the performance has improved considerably.

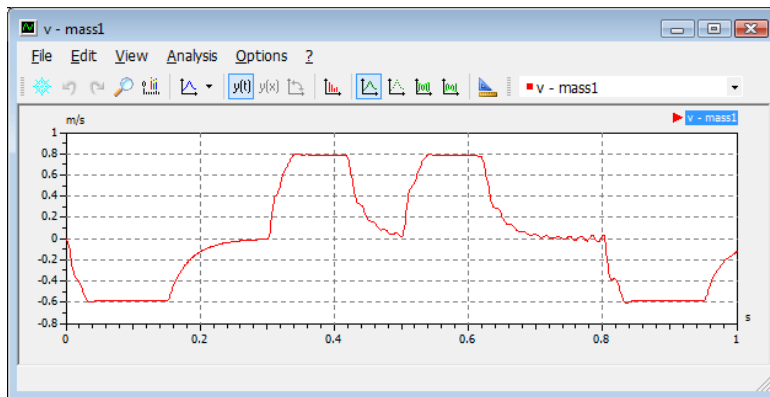

However if you open the result window for the mass velocity, you will see that the system tends to be unstable.

Figure 8: Simulation result with a gain of 50

If such an effect occurs in reality, the gain must be decreased. However, in your model you have neglected the dynamic behavior of the control valve. Therefore, you have to include the dynamics of the valve by editing the following parameters of the "ProportionalControlValve":

Table 5: New parameters of "ProportionalControlValve"

<p><i>ProportionalControlValve</i></p>	<ul style="list-style-type: none"> Activate the valve dynamics: <input checked="" type="checkbox"/> Consider Valve Dynamics Set the undamped "Natural Frequency" to 18 Hz and the "Damping Ratio" to 0.8:
--	---

