

Application

Modeling and Simulation of a Free-Piston Stirling Engine

Introduction and Overview

Stirling engines – engines which run “on hot air” - are designs which were already patented in 1816. They have a variety of advantages compared to other kinds of engines:

- *Running on any type of fuel*
- *Comparatively compact and lightweight design*
- *Quiet running due to the lack of internal combustion*
- *Low maintenance requirements since the working gas is enclosed in the engine interior, which can be sealed from the outer world.*

Those engines nowadays mostly still cover application niches in fields such as power generation (decentralized power supplies, spacecraft power supplies) or submarine drives.

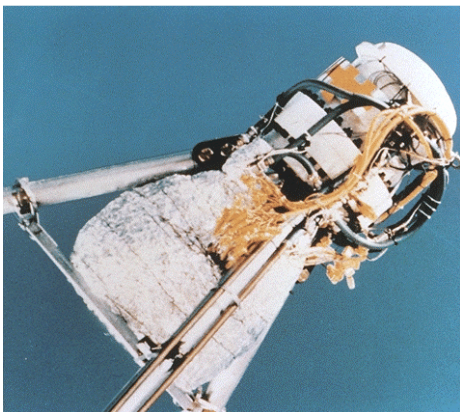

Figure 1: Prototype of a free-piston Stirling engine for a solar power unit from CumminsPower Generation

Source: <http://solstice.crest.org/renewables/dish-stirling/chapter7/free-piston.html>

Nevertheless, a permanently growing interest can be observed. The reverse problem – the application of the Stirling principle for the heat pumps or coolers - was solved with much greater success. One major obstacle for applications of Stirling engines as sources of mechanical power is the fact, that the design of an engine with a satisfying efficiency is a challenging task which is very hard to realize.

The behavior of such engines is very sensitive to design parameters and thus arriving at a successful solution not only requires a deep understanding of the physics, but also extensive tuning in the final design.

Simulation can help a lot in evaluating the behavior already in an early stage of the development and can push forward the rise of the Stirling engine to a successful and widely applied form of power supply.

In this application brief a test model is described, showing that ITI's **SimulationX** is capable to handle such a simulation problem, including the thermodynamics of the gas inside the engine. The attempt was made in cooperation with ENERTEC srl (enertec.mail@libero.it) an Italian company that is approaching the development of a configuration of the free-piston Stirling machine and provided the actual test configuration. The modeling was aiming at the implementation of a running machine based on mechanical design data plus some operational estimates, such as power output, operating temperatures, or working gas.

The remaining parameters were found by model tuning. Obtaining a good efficiency is one of the tricky parts in designing a Stirling engine, so there is still room for improvements and tuning in the model.

- *Multidisciplinary system modeling including all physical domains to the required extend*
- *Comprehensive models mapping all relevant effects*
- *Specification of working gases and mapping of the gas behavior with ideal or real gas models*
- *Running engine model exhibiting a Stirling cycle*
- *Model development and tuning from a limited set of parameters*

On the way between the work volumes the gas passes a so called regenerator, which is a heat storage, precooling the gas before it enters the compression space and preheating it on the way back and thus increasing efficiency. The principle Stirling engine structure can be seen in Figure 2.

In a free-piston engine the piston reciprocates against a gas or metal spring only, the displacer is completely free or also acts against a spring.

In operation the spring-mass configurations resonate with the movement of the gas between the work volumes.

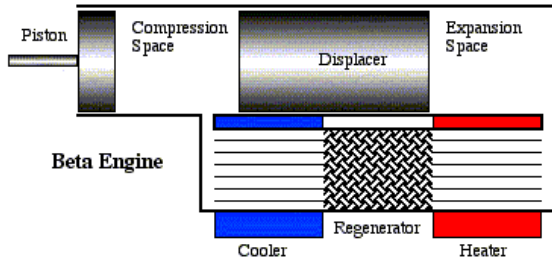

Figure 2: Principal structure of free-piston Stirling engines
 Source: <http://www.ent.ohio.edu/~urieli/stirling/engines/beta.html>

Free-Piston Stirling Engines – Modeling

The target design in this modeling study was a free-piston Stirling engine, where the piston drives a linear alternator for the generation of electrical power. Such a machine incorporates a multitude of physical domains:

- *Mechanics (piston and displacer, springs)*

- *Pneumatics (working gas behavior, thermodynamic cycle of the gas, cylinder(s), work and dead volumes, flow resistances)*
- *Thermics (heat flow in expansion and compression space, heat capacity of the regenerator, thermal losses, etc.)*
- *Magnetics (Magnetic fields in the alternator)*
- *Electrics (Alternator coils, distribution of generated power to an electrical network)*

All these domains are covered by **SimulationX**, so the creation of sophisticated and highly detailed models is possible. For the demonstration purpose a simplified approach was chosen, which was limited to the domains Mechanics, Pneumatics (including: heating and cooling with constant wall temperatures and heat transfer coefficients in the work volumes, behavior of carbon dioxide as the working gas), and Thermics (for the regenerator heat capacity). The alternator was modeled as a mechanical load (damper). Figure 3 shows the resulting simulation model. In order to avoid geometrical specifications for the spring preloads, force elements were used, which allows zero-centered coordinates. The cylinders both act with one chamber only, the other being linked constantly atmospheric pressure. The model has been parameterized using the machine's design sheets and operational parameters provided by the initiator of the task. Non-specified parameters were tuned towards a working engine. CO₂ was selected as the working gas using a real gas model based on the Bender equation of state.

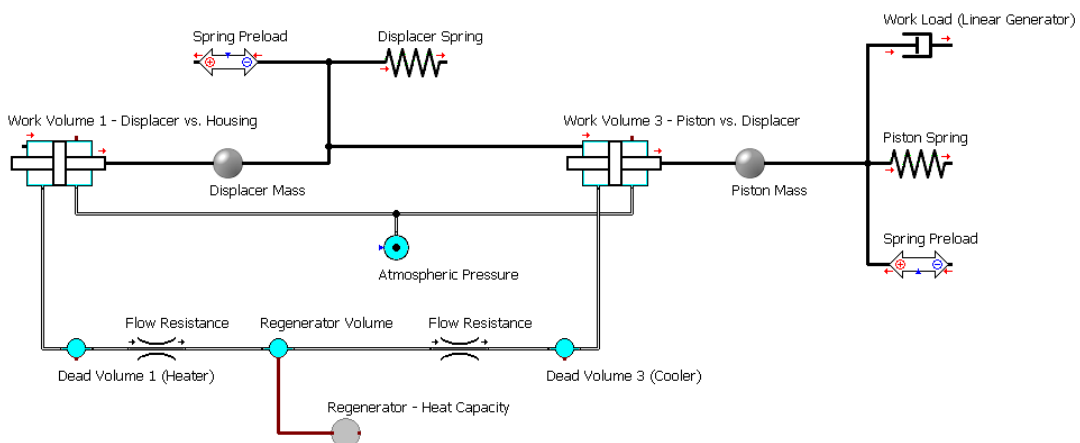

Figure 4: SimulationX model of the free-piston Stirling engine

Simulation

The core aim of the simulations was to show, that the model actually runs and that the behavior is based on the execution of a thermodynamic cycle, which corresponds to the behavior described in the literature.

As seen from the motion curves of the mechanical parts (piston and displacer), the model starts to operate very quickly (Figure 5).

It can be clearly observed, that piston and displacer reciprocate with a phase shift, which is essential for the operation of the engine.

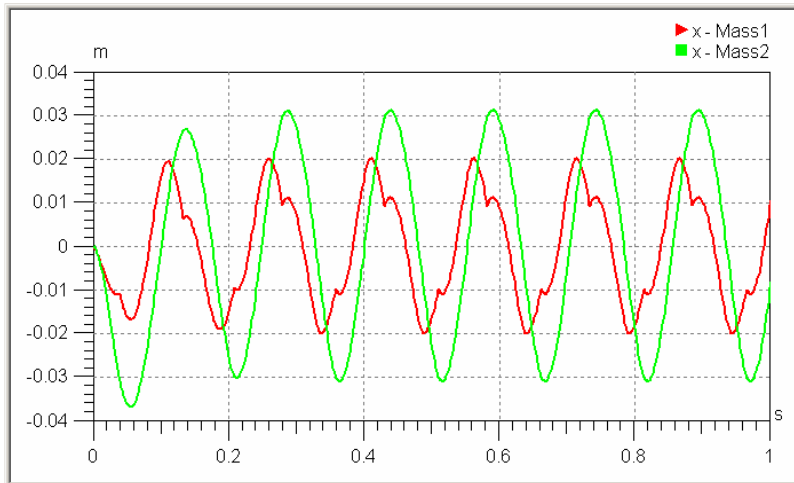

Figure 5: Simulated movement of piston and displacer in the engine (Mass1 – displacer, Mass 2 – piston)

Figure 6 shows, that the model indeed fulfills a Stirling cycle. The figure plots the pressure in the cooler vs. the total volume contained in the machine.

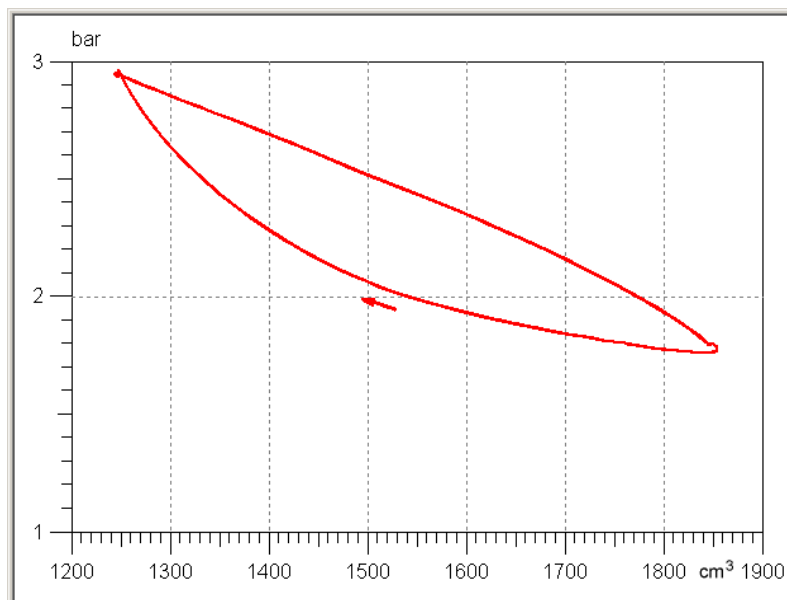

Figure 6: Stirling cycle of the engine model (pressure in the cooler vs. total volume)

One of the main, but hard to achieve, design goals of Stirling engines is a good engine efficiency, i.e. an as high as possible ratio between the supplied thermal energy and the received mechanical work. In SimulationX the heat flow (thermal power) through the wall of the heater is available as a result quantity, as well as the power consumed by the mechanical load. From these the total energies can be calculated by integration over time. The efficiency then follows as the quotient of the energies. These operations were modeled by a signal structure, which is shown in Figure 7.

Figure 8 displays the thermal power input and the mechanical power output of the engine.

In this test model no efforts were undertaken towards efficiency tuning, so there certainly is room for improvements.

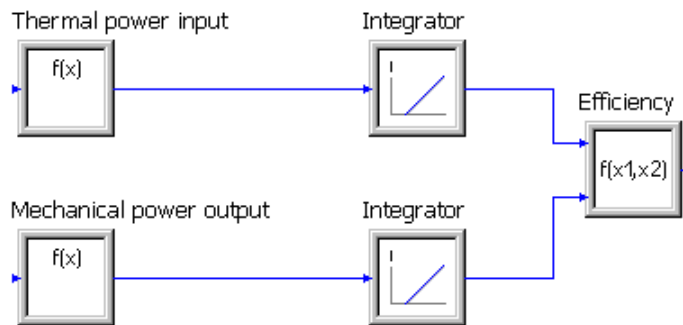

Figure 7: Signal processing structure for the calculation of the engine efficiency

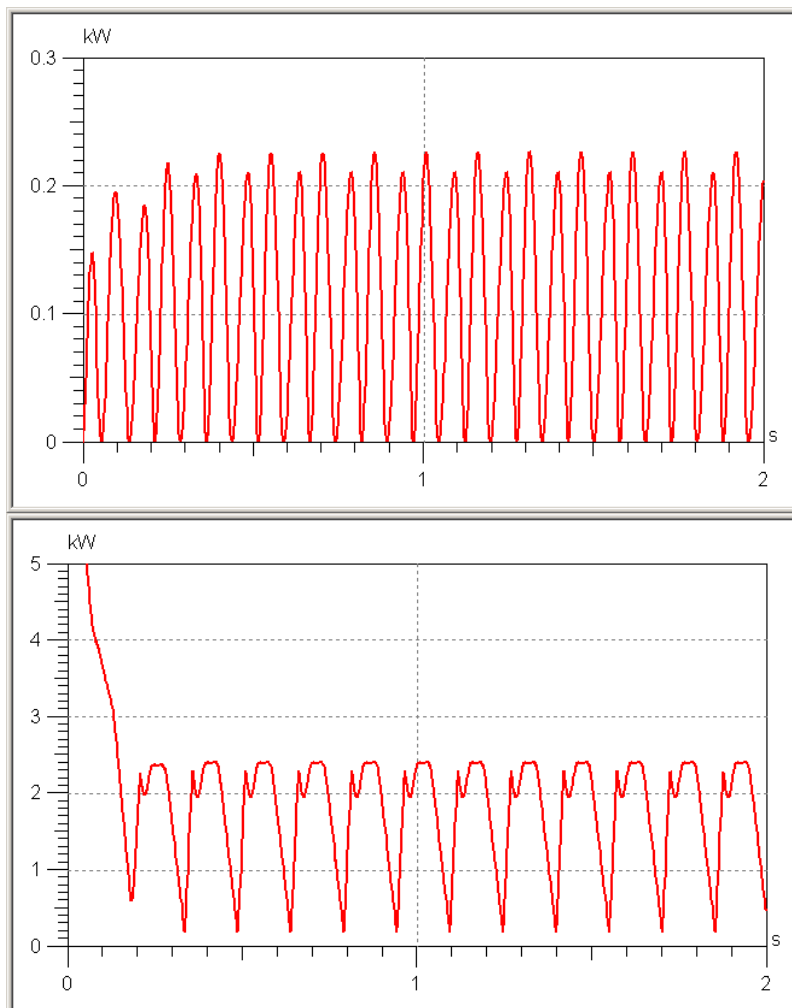

Figure 8: Thermal power input (top) and mechanical power output (bottom)